

# The feeble phantom

By Jörg Wuttke

Like mischievous ghosts, poorly-designed 48 V phantom power supply circuits can play mysterious tricks on their users. The ability of your microphones to handle high sound levels can be reduced considerably, problems of wind noise and solid-borne sound can increase, and overall sound quality can suffer while the underlying cause remains invisible.

## Why we have standards

What would be your likely response if your power company suddenly started to deliver only half the normal voltage? Most of your electrical equipment would malfunction, but you wouldn't waste much time blaming the makers of that equipment, once you realised that the power company had caused the problem.

Of course suppliers of power do not just go about changing their voltage unannounced; they follow established standards. Whenever such standards are to be changed, as with the increase of European mains voltage from 220 to 230 V, you can generally find out in advance how that will affect you.

No one is suggesting that we should increase the standard voltage for phantom powering. There have long been complaints, in fact, that such a high voltage was chosen in the first place, but to polarise a capacitive transducer requires a relatively high voltage and in the early days of solid-state circuitry efficient DC-DC converters were not yet available.

## The troubled history of phantom powering

Given these conditions, first-generation FET microphones often applied the phantom supply voltage more or less directly to polarise the capsule. The current consumption of the amplifiers had to be kept low so as to minimise voltage loss in the phantom supply resistors and to allow the 48 volts to be derived from the low-current anode power supplies in existing tube mixing desks. Such microphones generally used a single field-effect transistor as their

only active device, drawing less than 1 mA. Therefore an upper limit of 2 mA per microphone was set when phantom powering was first standardised.

Just in passing, it is worth noting that in many tube microphone circuits, the anode supply (often 120 VDC) was also used for capsule polarisation. Even when divided in half, as was often the case, it was still distinctly higher than 48 V. Thus the capsules for some 48 V transistorised microphones had to be constructed differently from their higher voltage tube counterparts. Devotees of vacuum tubes should be careful not to credit the tube itself for all differences in sound between tube microphones and their solid-state successors!

The use of a low phantom supply current had at least one major disadvantage: if one signal lead were shunted to ground—which could easily occur when connecting an unbalanced microphone, for example —7 mA would suddenly be drawn through the corresponding feed resistor. In a two-channel device built to supply only 2 mA per channel, the powering for both channels would collapse. That is only one of several “problem scenarios” that reveal an inherent unreliability in such an approach.

Of course as a rule, phantom powering should be turned off when an input circuit is to be run in an unbalanced configuration. But in practice this rule tends to be forgotten, and not all mixers have individual switches for the microphone powering on each input. Thus special measures must be taken to prevent adverse effects upon other channels.

When a power supply falters but does not collapse entirely, the symptoms may go unrecognised but microphone performance can still suffer in a variety of ways. In particular, the maximum undistorted output level of a microphone is

critically dependent on the power supply. Once the supply voltage falls below the tolerance limit, a few volts of sag can reduce the SPL limit of a microphone by more than a few decibels. An orchestral *fortissimo* might not sound nearly as good as it would with full microphone powering—and since most musicians do not usually play at full volume while rehearsing, the overload could come as a very unpleasant surprise during a concert performance.

A microphone's response to breath noise and wind can be affected, too, since membrane excursions due to air motion are essentially no different from excursions due to sound. Similarly, solid-borne noise (shock) can overload an underpowered microphone. When infrasonic signals overload a microphone's internal amplifier, even the steepest low-cut filter in a preamp or mixer "downstream" can do nothing to prevent audible distortion products.

### Modern phantom supplies with increased current

Today people expect power. The circuitry of a condenser microphone is not a power amplifier, but it requires a certain amount of power to deliver high output voltages at the lowest possible output impedance. And as a generalisation, semiconductor circuits tend to use high currents rather than the high voltages required by established tube circuits.

In 1979 the current allowed to be drawn by 48 V ("P48") condenser microphones was raised to 10 mA according to DIN 45596 [referred to as IEC 61938 since December 1996, and since July 1997 as DIN EN 61938]. Under short-circuit conditions 14 mA could be drawn, though no voltage would then reach the microphone. The current actually drawn by modern condenser microphones is typically at least 2 mA, with many products requiring 3 to 5 mA and occasionally even more. Microphones requiring the full 10 mA allowed by the standard do exist in the market; see *Rycote Microphone Data Book 2001*, Chris Woolf.

Unfortunately many phantom power supplies fail to meet the standard's requirements. Most 48 V supply circuits are not products of microphone manu-

facturers — instead, they are designed by the makers of mixing desks, outboard preamps, DAT recorders etc. Sadly, it must be said, that some of these vendors seem unaware that phantom powering is subject to any standards at all.

Recording engineers quite understandably want unrestricted freedom to audition and choose any kind of microphone. To that end they should insist that the equipment powering their microphones comply with the phantom powering standard; reviewers of recording equipment would do their readers a great service by checking for such compliance. Nearly all that would be needed is a multimeter and a basic knowledge of Ohm's Law.

A simple test for correct P48 phantom powering is:

1. Connect all the condenser microphones that you want to use simultaneously — or perhaps one fewer, since for this test at least one microphone input needs to be unused. At that input socket, measure the voltage between the contact for pin 1 (= ground) and the contact for either pin 2 or pin 3. This will tell you the central supply voltage that is available under the load of the connected microphones; it should be between 44 and 52 Volts.
2. Leaving the microphones connected as above, set the meter to read current and measure between pin 1 and pin 2, or between pin 1 and pin 3, of the unused XLR socket. This will temporarily create a short circuit at that point. The current should be between 6.5 and 7.7 mA—which will tell you whether the supply is sufficient to power modern, transformerless condenser microphones.

(If the phantom supply is configured using the transformer arrangement in Figure 2 then the short circuit current should be approx. 14 mA.)

A short circuit in one lead should have little effect on any other channel(s) powered from the same central supply; it should maintain its tolerance of  $\pm 4$  V. Transformers and supply resistors intended for use in phantom powering circuits must be able to withstand such conditions, since this type of accidental short circuit is always possible in the real world.

## Matching the supply resistors for symmetry

There is one further requirement for a good phantom supply circuit. The absolute value of the supply resistors is not critical ( $\pm 20\%$ ), but symmetry of the entire input circuit is of the greatest importance—therefore the two supply resistors must be as nearly identical in value as possible. It is strange that the manufacturers of certain mixing desks boast so proudly of the common mode rejection of their input circuits, yet pay no attention to this aspect of the phantom powering circuit. Where could

there be a greater need for common mode rejection than at the microphone inputs?

The standard requires rather modestly that the resistors in any one pair differ in actual value by no more than 0.4%. 1% tolerance resistors, which allow a difference of nearly 2% within a random pair, are inadequate unless specially selected. Yet some manufacturers use unselected resistors of even wider tolerance, apparently for reasons of cost. The customer/victim can rarely determine why these “balanced” inputs may then have problems with interference.

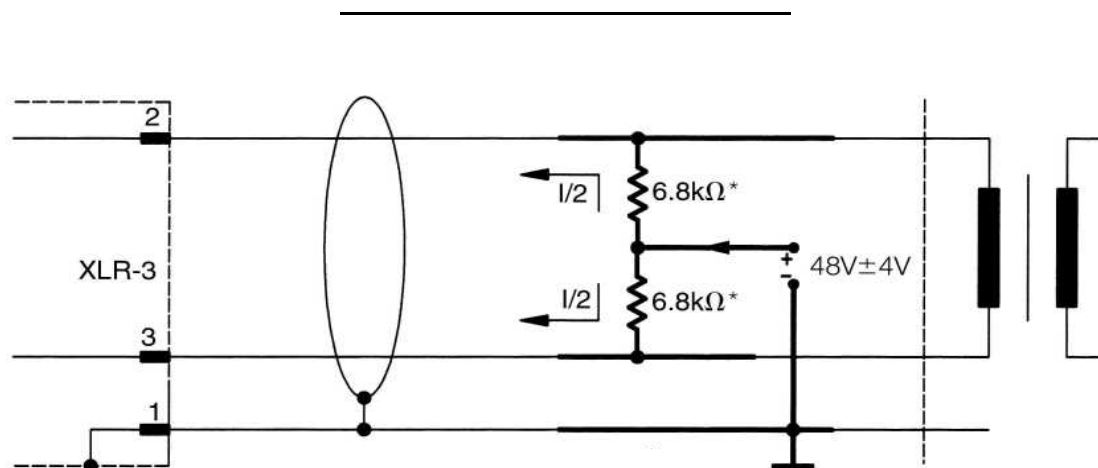

\* See text with regard to tolerance and

**Figure 1 - A standard 48 Volt phantom powering arrangement (console or microphone preamplifier shown with input transformer)**

## DC across the input transformer

When choosing an input transformer it is important to know how it will react in the event of a momentary or continuous flow of DC current. The transformer core should be of a type that will not retain a harmful degree of magnetisation from such occurrences.

In normal operation, phantom supply current flows in equal amounts through the two supply resistors, causing an equal voltage drop across them. Thus the two signal leads should be at the same DC potential, and if an input transformer is used, it can be connected directly. But any mismatch of supply resistors will result in a DC potential difference across the input, and a corresponding DC current will then flow continuously through the transformer

primary. Momentary DC current most often flows while a microphone is being attached to a cable, since not all contacts are made at exactly the same instant.

Even transformer manufacturers cannot always say how their products will react in such a situation; it is not something that is often considered. Experience may not indicate that this problem has readily audible results, but it does create an “uncertainty factor.” Perhaps it shouldn’t surprise us if different input channels on the same mixer sound slightly different from one another, despite identical measured audio-frequency performance; it could be a consequence of differently [mis]matched supply resistors. Naturally this problem does not occur with transformerless inputs

but a transformer's advantage in obtaining galvanic isolation and essentially perfect symmetry should not be undervalued.

Protecting an input from DC with coupling capacitors in front of a transformer is undesirable on several grounds. Capacitors of the necessary values are bulky and expensive, and seen from a technical standpoint they influence the impedance conditions of the input circuit in an unfavourable way. At the lowest frequencies they create a near-open-circuit condition at the input, thus compromising the unweighted signal-to-noise ratio.

### 12 V and 24 V phantom powering

48 V at 10 mA/channel is admittedly a tough requirement, especially for battery-powered supplies. 12 V phantom powering can be a better solution in many respects. It obviates the need for costly, inefficient DC converter circuits in the supply, while the microphone can still be as "power-capable" as a 48 Volt type. The standard value of the supply resis-

tors for 12 Volt phantom powering is  $680\Omega$ . The marketplace, however, has decided in favour of 48 Volt phantom powering.

As an "improved" method to make more power available to the microphone amplifier, a 24 V phantom powering standard was created in 1979, with supply resistors of only  $1.2\text{ k}\Omega$  being specified. It was envisioned that all future equipment might follow this standard. Today, we can say that this idea arrived too late. No equipment manufacturer could get by with 24 V powering alone; 48 V would have to be available as well. Conversely no microphone manufacturer would dare to offer a product that worked only with 24 V powering. But if all microphones work at 48 V as well as at 24, why should the manufacturers of preamps, mixing desks, etc. drive up their costs to add 24 V powering? The advantages offered by this system are simply not persuasive enough, and it seems likely that 24 V powering will be dropped from future editions of the standard.

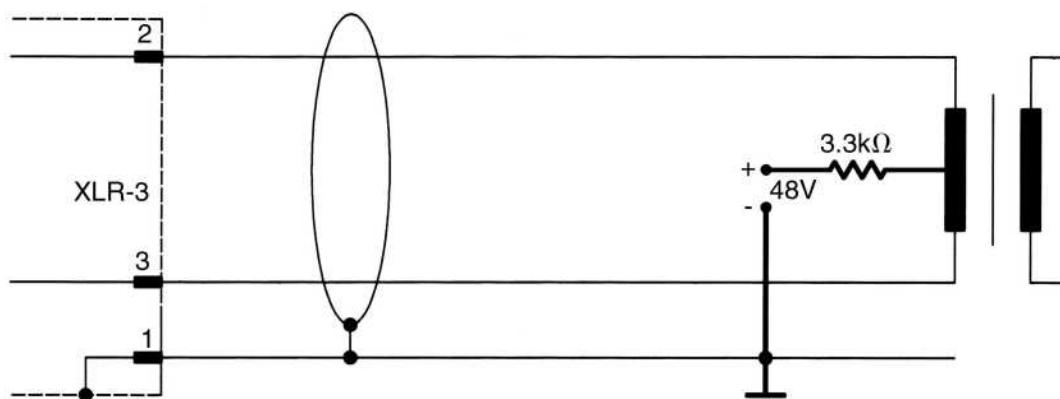

*Figure 2. - An alternative 48 Volt phantom powering arrangement with centre-tapped input transformer*

### Other phantom powering methods

In addition to the standard phantom powering method shown in Figure 1, there exists the alternative approach shown in Figure 2. It requires an input transformer with a centre-tapped primary winding. The 48 V supply current is fed through half the usual resistance to the centre point of the

primary. If the two halves of the transformer primary have good actual symmetry, there is nothing inferior about this circuit type. But there must be equality and balance not only between the DC resistance of the "half-windings," but also in the magnetic flux induced in the transformer core.

For 24 V and especially 12 V powering, this method offers one distinct advantage: the supply resistors will not load down the microphone signal as much as they do in the arrangement of Figure 1. [The 6.8 kΩ resistors used in 48 V powering are high enough in value to avoid this problem.]

A particularly elegant alternative method of phantom powering involves an active circuit — an “electronic inductance” — that meets the DC requirements of the microphone but has a high AC impedance. This approach can increase the immunity of the system to interference of various kinds, but for reasons of cost it is seldom used today.

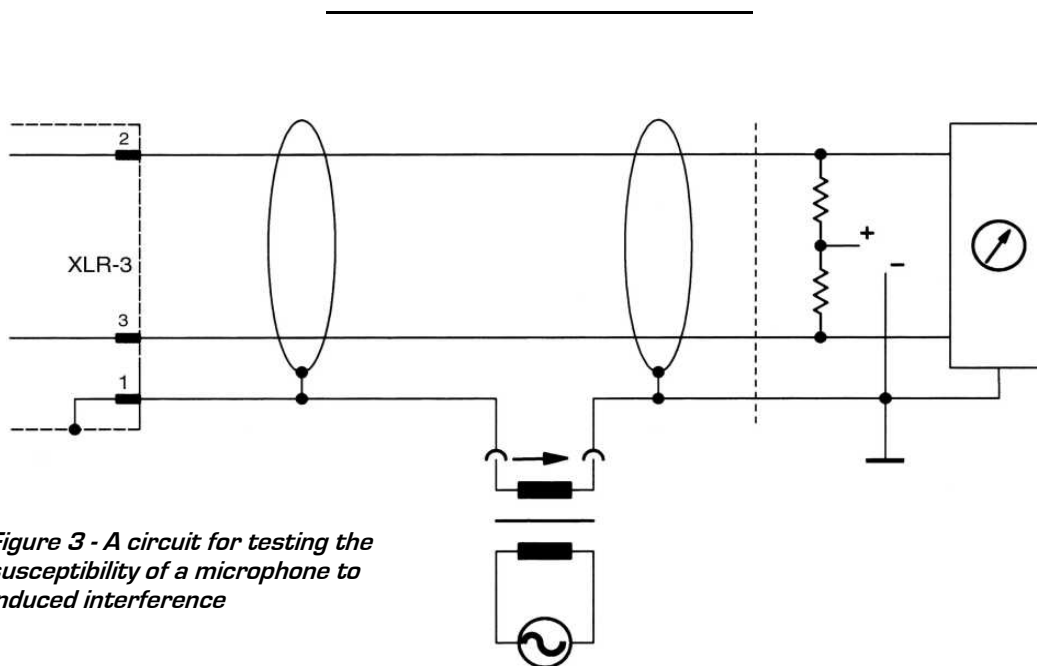

Figure 3 - A circuit for testing the susceptibility of a microphone to induced interference

### Suppressing interference

Figure 3 shows a well-established scheme for investigating and measuring interference under conditions that closely duplicate actual usage. Since the interference signal is in series with the phantom powering, the results can also reveal any shortcomings in the phantom supply circuit such as poor regulation or filtering, crosstalk among channels via the shared supply, etc. This type of measurement was routinely carried out by the Institute for Radio Technology (IRT) for all microphones to be used by the German broadcasting services. It gives an index of immunity to induced interference.

The value of this index in decibels is calculated with the formula  $B = 20 \log_{10} [V_0 / V_1]$ , where  $V_0$  is the “interference” voltage induced experimentally into the cable and  $V_1$  is the remnant of this voltage detected in the output. This value should be greater than 60 dB, e.g. a 1 Volt interference

signal should leave less than a 1 mV trace in the output. High-quality microphones powered via well-matched pairs of resistors can easily attain 80 dB values across the whole audio spectrum. For even greater immunity, the previously mentioned “electronic inductance” approach can be used in the phantom power supply.

More could certainly be said on this topic, but it is still paramount that the very basics of phantom powering be carried out correctly — and in practice, that is very often not the case.

### The simplest way to reduce interference: switch off the microphone pad!

One of the advantages of condenser microphones over dynamic types is that given the same sound pressure levels, condenser microphones will produce signals that are typically about 20 dB higher in level. As a result, the ability of a condenser microphone to suppress interference simply by over-

powering it with signal is much greater than that of a dynamic microphone.

Older, low-current condenser microphone amplifiers tended to clip at sound pressure levels not far above 120 dB SPL. The use of a “pad” was the only way for these microphones to handle higher sound pressure levels at all. But modern condenser microphones (with 2 mA or higher supply current) can readily accept sound pressure levels higher than those which their predecessors could handle even *with* a pad. Unfortunately many users of microphones expect to see a pad switch on every condenser microphone, and some manufacturers have made it a prime duty to meet this expectation. But if an internal pad is used on a modern microphone, its maximum sound pressure level will then be so high as to have little practical value beyond creating impressive specifications. It is usually better for an engineer to think than to use that switch. The level of any interfering signals, and the inherent noise output of the amplifier, will remain nearly constant whether a pad is used or not. Thus the signal-to-noise and signal-to-interference ratio of the microphone is lowered when an internal pad is used.

The output level of a condenser microphone can be a volt or more at the highest sound pressure levels. A microphone pad may be justified if a preamp input circuit cannot handle these levels without overloading. Still, the front end of the microphone is the worst possible place for such a pad; a much better place for it is at the opposite end of the cable, right at the input itself. Not only would the signal then be reduced, but also the noise output voltage of the microphone and any interference that had been induced into the cable. If the input itself is quiet enough there will be no decrease in signal-to-noise performance.

Figure 4 shows a schematic diagram for a balanced, resistive pad; similar ones are sold ready made as in-line accessories. This type of pad does not interfere with phantom powering. As we have pointed out, the absolute value of phantom resistors is not critical, and the pair of 240 Ω resistors in the pad circuit are merely in series with them; so just as with the phantom supply resistors, the most important concern is that those two resistor

values be matched as closely as possible to one another. The impedances in the overall circuit are within normal bounds for studio equipment; a pad like this and a microphone having 40Ω output impedance, for example, will yield a net output impedance of 190Ω .

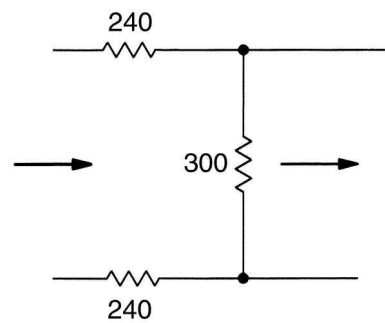

**Figure 4 - Balanced resistive pad, suitable for use with phantom-powered microphones**

### A closing thought

In the light of today's generally higher expectations for sound quality, and the spirited discussion of marginal sonic differences ascribed to tubes vs. transistors, 48 kHz or 96 kHz sampling rate, etc., it is time to drive away some real demons. There is no excuse for the severe adverse effects on high-quality sound production that are caused by carelessly executed phantom powering.

*(Translation: David Satz)*

*Jörg Wuttke studied electronics and telecommunications at Karlsruhe University, specialising in acoustics. He joined Schoeps GmbH as a re-search engineer in 1970, became its Chief Engineer in 1972, and is now its Technical Director. He has been an active member of the Audio Engineering Society for many years. and in 1993 he was awarded an AES Fellowship. Since 1972, he has also been a member of the DIN Standards Committee on Microphones and Headphones. He maintains an avid interest in listening to music and recording live concerts.*